

# GREISINGER

Member of GHM GROUP

## Compact manual

EN

# G 1791

One-hand soil-/compost-thermometer



Members of GHM GROUP:

**GREISINGER**

**HONSBERG**

**Martens**

**DeltaOHM**

**VAL.CO**

# Table of contents

<b>1</b>	<b>About this documentation</b> .....	<b>4</b>
1.1	Foreword .....	4
1.2	Legal notices .....	4
1.3	Further information .....	4
<b>2</b>	<b>Safety</b> .....	<b>5</b>
2.1	Explanation of safety symbols .....	5
2.2	Foreseeable misuse .....	5
2.3	Safety instructions .....	6
2.4	Intended use.....	7
2.5	Qualified personnel.....	7
<b>3</b>	<b>The device at a glance</b> .....	<b>8</b>
3.1	Display elements .....	8
3.2	Connections .....	8
3.3	Operating elements .....	9
<b>4</b>	<b>Operation</b> .....	<b>10</b>
4.1	Opening the configuration menu .....	10
4.2	Adjustment of the measuring input.....	12
<b>5</b>	<b>Measurement Basics</b> .....	<b>13</b>
5.1	Measurement in the soil, ... ..	13
5.2	Possible measuring errors .....	13
5.2.1	Immersion depth.....	13
5.2.2	Surface effects and poor heat transfer .....	13
5.2.3	Cooling / evaporation.....	13
5.2.4	Response time .....	13
<b>6</b>	<b>Operation and maintenance</b> .....	<b>14</b>
6.1	Operating and maintenance notices.....	14
6.2	Battery.....	14

---

6.2.1	Battery indicator.....	14
6.2.2	Changing battery .....	14
<b>7</b>	<b>Error and system messages.....</b>	<b>16</b>
<b>8</b>	<b>Technical data .....</b>	<b>17</b>
<b>9</b>	<b>Disposal .....</b>	<b>18</b>
<b>10</b>	<b>Service .....</b>	<b>19</b>
10.1	Manufacturer .....	19
10.2	Calibration and adjustment service .....	19

# 1 About this documentation

## 1.1 Foreword

Read this document carefully and familiarise yourself with the operation of the device before you use it.

Keep this document ready to hand and in the immediate vicinity of the device so that it is available to the personnel/user for reference at all times in case of doubt.

The user must have carefully read and understood the operating manual before beginning any work.

## 1.2 Legal notices

The liability and warranty of the manufacturer for damages and consequential damages are voided with misuse, disregarding this document, disregarding safety notices, assignment of inadequately qualified technical personnel and arbitrary modifications of the device.

This document is entrusted to the recipient for personal use only. Any impermissible transfer, duplication, translation into other languages or excerpts from this operating manual are prohibited.

The manufacturer assumes no liability for print errors.

## 1.3 Further information

Software version of the device:

- V1.2 or later

For the exact product name, refer to the type plate on the rear side of the device.

### **NOTE**

For information about the software version, press and hold the ON button to switch on the device for longer than 5 seconds. The series is shown in the main display and the software version of the device is shown in the secondary display.

## 2 Safety

### 2.1 Explanation of safety symbols

#### **DANGER**

This symbol warns of imminent danger, which can result in death, severe bodily injury, or severe property damage in case of non-observance.

#### **CAUTION**

This symbol warns of potential dangers or harmful situations, which can cause damage to the device or to the environment in case of non-observance.

#### **NOTE**

This symbol indicates processes, which can have a direct influence on operation or can trigger an unforeseen reaction in case of non-observance.

### 2.2 Foreseeable misuse

The fault-free function and operational safety of the device can only be guaranteed if applicable safety precautions and the device-specific safety instructions for this document are observed.

If these notices are disregarded, personal injury or death, as well as property damage can occur.

#### **DANGER**

##### **Incorrect area of application!**

In order to prevent erratic behaviour of the device, personal injury and property damage, the device must be used exclusively as described under intended use.

- Do not use in safety / Emergency Stop devices!
- The device is not suitable for use in explosion-prone areas!
- The device must not be used for diagnostic or other medical purposes on patients!
- Not suitable for use with requirements on functional safety, e.g. SIL!

## 2.3 Safety instructions

### CAUTION

#### **Risk of injury at the temperature sensor!**

The insertion probes entail the risk of stab injuries due to the pointed probe design.

- Handle insertion probes with care!
- Fit a protective cap on the measuring probe if probe is not in use!
- Do not put the device down with the sensor tube pointing upwards.

There is a risk of burns when measuring in high (and very low) temperatures. Use gloves if necessary.

### CAUTION

Empty batteries and batteries of inferior quality can leak more easily, which can destroy the device. Please also observe the instructions in the chapter "Operation and maintenance".

### DANGER

There is an immediate danger to life if live parts come into contact with the temperature sensor!

Therefore, do not conduct measurements on or in the direct vicinity of live parts or lines. Never plug the temperature sensor into sockets, etc.

### NOTE

This device does not belong in children's hands!

### NOTE

Device and sensor are not designed for continuous contact with foods.

## 2.4 Intended use

The G 1700 - series is a water-protected thermometer for precise and temperature measurements.

The special design of the G 1791 makes it to a convenient insertion thermometer for:

- Soft soils
- compost
- agricultural windrows
- bulk material

## 2.5 Qualified personnel





For commissioning, operation and maintenance, the relevant personnel must have adequate knowledge of the measuring process and the significance of the measurements. The instructions in this document must be understood, observed and followed.

In order to avoid any risks arising from interpretation of the measurements in the concrete application, the user must have additional expertise. The user is solely liable for damages/danger resulting from misinterpretation due to inadequate expertise.

## 3 The device at a glance



### 3.1 Display elements

 Battery indicator	Evaluation of the battery status
 Unit display	Display of units or type of mode, min/max/hold
 Main display	Measurement of the current temperature or value for min/max/hold
 Auxiliary display	Measurement of the current temperature in min/max/hold mode with unit

### 3.2 Connections

Probe	Permanently connected sensor
-------	------------------------------



### 3.3 Operating elements



#### On / Off button

Press briefly

Switch on the device

Activate / deactivate lighting

Long press

Switch off the device



Reject changes in a menu



#### Up / Down button

Press briefly



Display of the min/max value



Change value of the selected parameter

Long press



Reset the min/max value of the current measurement

Both simultaneously



Rotate display, overhead display



#### Function button

Press briefly



Freeze measurement (Hold)



Call up next parameter

Long press, 2s



Start menu "configuration",  $\text{CONF}$  appears in the display

Operating status  *device is in measured value display*





*device is in a menu*

## 4 Operation

### 4.1 Opening the configuration menu

1. Press the *Function key* for 2 seconds to open the **Configuration** menu.
2.  $\text{CONF}$  appears in the display. Release the *Function key*.

Parameter	Values	Meaning
	 	
$AL$	<b>Alarm</b>	
	$oFF$	No alarm active
	$oN$	Alarm via text insertion, acoustic signal and flashing of the background lighting
	$bEEP$	Alarm via text insertion and acoustic signal
	$L, tE$	Alarm via text insertion and flashing of the background lighting
$ALLo$	<b>Min. alarm limit</b> <i>(only available if AL &lt;&gt; off)</i>	
	$-70.0 .. ALHi$	a min. alert is triggered if the value falls below this value. (at °F: -94.0 .. AL.Hi)
$ALHi$	<b>Max. alarm limit</b> <i>(only available if AL &lt;&gt; off)</i>	
	$ALLo .. 250.0$	If the value is exceeded, a max. alarm is triggered. (at °F: AL.Hi .. 482.0)
$PoFF$	<b>Shut-off time</b>	
	$oFF$	No automatic shut-off
	$15, 30, 60, 120, 240$	Automatic shut-off after a selected time in minutes, during which no buttons have been pressed



$U_{1} E$	Backlight	
	<i>oFF</i>	Backlight deactivated
	<i>15, 30, 60, 120, 240</i>	Automatic shut-off of the backlight after a selected time in seconds, during which no buttons have been pressed
	<i>on</i>	No automatic shut off of the backlight
$U_{n} E$	Display unit	
	$^{\circ}C$	Temperature display in $^{\circ}C$
	$^{\circ}F$	Temperature display in $^{\circ}F$
$l_{n} E$	Factory settings	
	<i>no</i>	Use current configuration
	<i>YES</i>	Reset device to factory settings. After confirming with the <i>function-button</i> , the display shows: <i>l_{n} E donE</i>

## 4.2 Adjustment of the measuring input

The temperature input can be adjusted with the zero point correction and the gradient correction. If an adjustment is made, you change the pre-adjusted factory settings.

This is signalled with the display text  $t.oF$  or  $t.SL$  when switching on.

1. Switch the device off.
2. Hold the *down button* and press the *On/Off button* briefly to switch on the device and open the **Adjustment** menu.
3. The display shows the first parameter. Release the *down button*.

Parameter	Values	Meaning
	 	
$t.oF$	<b>Zero point correction</b>	
	0.00	No zero point correction
	-5.00 ... 5.00	Zero point correction in °C. (at °F -9.00 .. 9.00)
$t.SL$	<b>Gradient correction of the temperature</b>	
	0.00	No gradient correction of the temperature
	-5.00 ... 5.00	Gradient correction in %

### Formula used by device:

Temperature = °C: Display = (measured value -  $t.oF$ ) \* (1 +  $t.SL$  / 100)

Temperature = °F: Display = (meas. value - 32 °F -  $t.oF$ ) \* (1 +  $t.SL$  / 100) + 32 °F

### Adjustment example:

Temperature unit= °C, the adjustment is carried out in 2 separate steps at 0 °C (e.g. ice water) and at a reference temperature (e.g. clinical thermometer with water bath 37 °C).- First set the values of  $t.oF$  and  $t.SL$  in the adjustment menu to 0

Zero point: - Set the temperature probe to 0 °C and let it adjust.

- Start the adjustment menu and enter the display value at 0 °C for  $t.oF$
- After leaving the menu, the device should now display 0.0 °C.

Slope: - Set the temperature sensor to the reference temperature and let it adjust.

- Calculate slope correction:  $t.SL = \left( \frac{\text{reference temperature}}{\text{display}} - 1 \right) * 100$
- Start adjustment menu and enter the calculated value at  $t.SL$
- Exit menu, the device should now display the reference temperature.

## 5 Measurement Basics

### 5.1 Measurement in the soil, ...

Penetration into the medium to be measured should be done without exerting much force.

Try to exert the force in the axis of the probe tube to avoid creating a lever effect on the housing.

Never use tools (e.g. a hammer) to knock the sensor tube into the ground via the device housing!

If you encounter strong resistance when piercing (high compaction, stones), please try to pierce at another suitable place in order not to damage the tip or the device.

If this is not possible, you can also pierce an appropriate hole with another rod (e.g. reinforcing iron).



### 5.2 Possible measuring errors

#### 5.2.1 Immersion depth

Liquid, soil: Immerse to a depth of at least 100 mm (and then stir). Otherwise, measuring errors can occur due to the heat transmission of the sensor tube if the immersion depth is too shallow.

#### 5.2.2 Surface effects and poor heat transfer

Special measuring sensors are required for this purpose. Surface characteristics, design of the measuring sensor, heat transfer and environmental temperature influence the measurement result.

**NOTE:** Thermally conductive paste between the measuring sensor and surface can also increase measurement accuracy in some cases.

#### 5.2.3 Cooling / evaporation

When measuring the air temperature, the probe should be dry, otherwise the temperature measured will be too low.

#### 5.2.4 Response time

An adequate wait time must be observed for the measuring process before reading the measured value. The response time  $T_{90}$  describes the time in which the displayed measured value reached 90% of the end value.

## 6 Operation and maintenance

### 6.1 Operating and maintenance notices

#### NOTE

The device and temperature probe must be handled with care and used in accordance with the technical data. Do not throw or strike.

#### NOTE

Plugs and sockets must be protected from soiling.

#### NOTE

If the device is stored at a temperature above 50 °C, or is not used for an extended period of time, the batteries must be removed. Leaks from the batteries are avoided as a result.

### 6.2 Battery

#### 6.2.1 Battery indicator

If the empty frame in the battery display blinks, the batteries are depleted and must be replaced. However, the device will still operate for a certain length of time.

If the BAT display text appears in the main display, the battery voltage is no longer adequate for operation of the device. The battery is fully depleted.

#### 6.2.2 Changing battery

#### DANGER

##### **Danger of explosion!**

Using damaged or unsuitable batteries can generate heat, which can cause the batteries to crack and possibly explode!

- Only use high-quality and suitable alkaline batteries!

**⚠ CAUTION****Damage!**

If the batteries have different charge levels, leaks and thus damage to the device can occur.

- Only use high-quality and suitable alkaline batteries!
- Do not use different types of batteries!
- Remove depleted batteries immediately and dispose of them at a suitable collection point.

**! NOTE**

Unnecessary unscrewing endangers the protection against moisture and should therefore be avoided.

**! NOTE**

Read the following handling instructions before replacing batteries and follow them step by step.

If disregarded, the device could be damaged or the protection from moisture could be diminished.

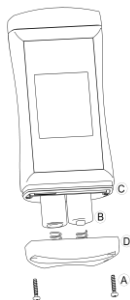

1. Unscrews the Phillips screws (A) and remove the cover.
2. Carefully replace the two Mignon AA batteries (B). Ensure that the polarity is correct! It must be possible to insert the batteries in the correct position without using force.
3. The O-ring (C) must be undamaged, clean and positioned at the intended depth.
4. Fit the cover (D) on evenly. The O-ring must remain at the intended depth!
5. Tighten the Phillips screws (A).

## 7 Error and system messages

Display	Meaning	Possible causes	Remedy
----	Measurement far outside of the measuring range Probe defect	Measurement outside of the measuring range Measuring probe or device defect	Stay within allowable measurement range Send in for repair
No display, unclear characters or no response when buttons are pressed	Battery depleted System error Device is defective	Battery depleted Error in the device	Replace battery Send in for repair
bAt	Battery depleted	Battery depleted	Replace battery
Err.1	Measuring range exceeded	Measurement too high Measuring probe or device defect	Stay within allowable measurement range Send in for repair
Err.2	Measuring range is undercut	Measurement too low Measuring probe or device defect	Stay within allowable measurement range Send in for repair
545 Err	System error	Error in the device	Switch device on/off Replace batteries Send in for repair



## 8 Technical data

G 1791	
Measuring range	-70.0 .. +250.0 °C (-94.0 .. +482.0 °F)
Accuracy	-20 .. +100 °C: $\pm 0.1 \text{ K} \pm 1 \text{ Digit}$ -70 .. +250 °C: $\pm 0.2 \%$ of measured value $\pm 2 \text{ digits}$
Probe	Pt1000, Probe tube firmly screwed underneath, similar T-handle
Probe tube	$\varnothing 8 \times 920 \text{ mm}$ , stainless steel
Probe tip	
Response time $t_{90}$	approx. 4 s (water (0,4 m/s))



Measuring cycle	approx. 2 measurements per second
Display	3-line segment LCD, additional symbols, illuminated (white, luminous duration adjustable)
Standard functions	Min/max/hold, alarm (optical and acoustic)
Adjustment	Offset and gradient correction
Housing	Break-proof ABS housing
Protection rating	IP54
Dimensions L*W*H	108 * 54 * 28 mm, device without probe tube
Weight	~ 285 g incl. batteries
Nominal temperature	25 °C
Operating conditions	-20 to 50 °C; 0 to 95 %RH (temporarily condensing)
Storage temperature	-20 to 70 °C
Current supply	2 * AA batteries (mignon)
Current requirement	approx. 0,4 mA, approx. 2 mA with backlight

battery life	Service life > 5000 hours with alkaline batteries (without backlighting)
Battery indicator	4-stage battery status indicator, Replacement indicator for depleted batteries: "BAT"
Auto-power-OFF function	The device switches off automatically if this is activated
Directives and standards	<p>The devices conform to the following Directives of the Council for the harmonisation of legal regulations of the Member States:</p> <p>2014/30/EU EMC Directive 2011/65/EU RoHS</p> <p>Applied harmonised standards:</p> <p>EN 61326-1:2013    Emission limits: Class B Immunity according to Table A.1 Additional errors: &lt; 1 % FS</p> <p>EN IEC 63000:2018</p> <p>The device is intended for mobile use and/or stationary operation in the scope of the specified operating conditions without further limitations.</p>

## 9 Disposal

Separation by material and recycling of device components and packaging must take place at the time of disposal. The valid regional statutory regulations and directives applicable at the time must be observed.

### NOTE



The device must not be disposed of with household waste. Return it to us, freight prepaid. We will then arrange for the proper and environmentally-friendly disposal.

Private end users in Germany have the possibility of dropping off the device at the municipal collection centre. Batteries must be removed beforehand!

Please dispose of empty batteries at the collection points intended for this purpose

## 10 Service

### 10.1 Manufacturer

If you have any questions, please do not hesitate to contact us:

Contact: GHM Messtechnik GmbH  
**GHM GROUP - Greisinger**  
Hans-Sachs-Str. 26  
93128 Regenstauf | GERMANY  
Email: [info@greisinger.de](mailto:info@greisinger.de) | [www.greisinger.de](http://www.greisinger.de)  
WEEE reg. no. DE 93889386



### 10.2 Calibration and adjustment service

The purpose of the calibration is to verify the precision of the measuring device by comparing it with a traceable reference.

Both ISO calibration certificates and DAkkS calibration certificates are available from Greisinger.

#### Explanation

The ISO standard 9001 is applied for the iso-calibration certificates.

These certificates are an affordable alternative to the DAkkS calibration certificates and provide information of the traceable reference, a list of individual values and documentation.

The DAkkS calibration is based on DIN EN ISO/17025, the accreditation basis is recognised worldwide. These certificates offer high-quality calibration and consistently high quality. The DAkkS calibration includes any necessary adjustment with the purpose of minimising a deviation of the measuring device.

#### NOTE

The device is delivered with a test report.

This confirms that the measuring device has been adjusted and tested, without making any statement about the accuracy of a temperature sensor.

#### NOTE

Only the manufacturer can check the basic settings and make corrections if necessary.